



# BEVERAGE-AIR

Project: _____	AIA#
Item: _____	
Location: _____	SIS#
Approved: _____	

## BAR EQUIPMENT- BACK BAR REFRIGERATOR

MODEL:  
BB24HC-1-B

BB24HC Solid Door  
Hydrocarbon Series

BB24HC BACK BAR REFRIGERATOR

5 Year Parts/Labor Warranty Available

7 Year Compressor Warranty



### CABINET CONSTRUCTION

- Exterior features durable black painted steel
- Interior construction utilizes galvanized steel on walls and ceiling, heavy duty stainless steel floor
- Mechanical control
- 1 ½" Stainless steel top
- Two (2) epoxy coated wire shelves
- Self-closing door with 120° stay-open feature
- Door lock
- Field reversible door (hinge kit not included)
- LED lighting
- Magnetic gaskets provide positive door seal
- Packaged products only
- 4" Heavy duty casters two (2) with locks
- Balanced, forced air refrigeration system provides rapid chilling of product

### OPTIONS & ACCESSORIES

- 3 Year parts/labor standard, additional 2 year warranty available
- For stainless steel interior (refer to -F models)
- Wine model (40°-60° models)
- Underbar model option
- Galvanized sub-top

### REFRIGERATION SYSTEM

- Uses environmentally friendly, energy efficient R290 refrigerant, and meets all regulatory requirements for CARB, SNAP, DOE & more
- Adaptive defrost
- Epoxy coated evaporator coil
- Maintains product temperature between 36°F and 38°F



Please verify qualifying units by visiting:  
[www.energystar.gov/cfs](http://www.energystar.gov/cfs)

3779 Champion Blvd., Winston-Salem, NC 27105  
1-888-845-9800 Fax: 1-336-245-6453  
Beverage-Air.com Sales@bevair.com



# BEVERAGE-AIR

MODEL	BB24HC-1-B
<b>EXTERNAL DIMENSIONAL DATA</b>	
Width Overall	24"
Depth Overall	30 1/8"
Height Overall with Casters	37 3/4"
Number of Doors	1
Depth with Door Open 90°	50 3/4"
Door Opening (in)	19 3/4" x 28"
<b>INTERNAL DIMENSIONAL DATA</b>	
NET Capacity (cubic ft.)	7.66
Internal Width Overall (in)	20"
Internal Depth Overall (in)	22 1/4"
Internal Height Overall (in)	29 1/2"
Number of Shelves	2
Number of 1/2 Kegs	1
<b>ELECTRICAL DATA</b>	
Full Load Amperes	2.0
<b>REFRIGERATION DATA</b>	
Horsepower	1/6
Capacity (BTU/Hr)	1094
Heat Rejection (BTU/Hr)	1641
Charge (lbs/grams)	0.1213/55
<b>SHIPPING DATA</b>	
Gross Weight - Crated	186 lbs
Height - Crated	46"
Width - Crated	27"
Depth - Crated	32"

\*NOTE: Remote units are field wired and come with 6" legs.  
Refrigerant must be specified at time of order.

## Bar Equipment-Back Bar Refrigerator Model: BB24HC-1-B

### Model Views

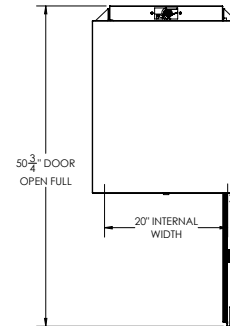

### PLAN VIEW

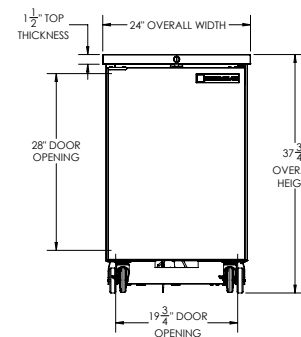

### ELEVATION VIEW

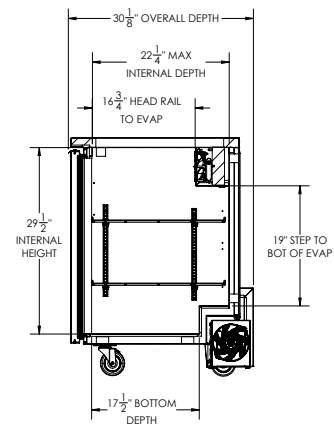

### SIDE VIEW



### ELECTRICAL CONNECTION

115/60/1  
NEMA 5-15P

Unit pre-wired at factory  
and include 8' long cord  
and plug set.